

swimming pool **COMPLIANCE** **GUIDE**



accessibility **equipment**



MORE ACCESSIBLE POOLS

Access to aquatic environments is vitally important for both mobility challenged individuals and seniors. A pool provides the optimal setting for low impact exercise or therapy. Fear of falling and other traditional land-based concerns virtually disappear when exercise is moved into the pool. As our society ages the mobility challenged population increases, as does the need for safe and accessible pools. Our line of powered lifts can help make pools more accessible starting today.

POOLLIFTS.COM

ADA Pool Accessibility requirements became law on September 15, 2010. This new legislation requires commercial swimming pools to provide means of access for their pools on or before March 15, 2012. Poollifts.com is an informational website dedicated to helping the swimming pool industry meet the new ADA Pool Accessibility requirements. Find whitepapers, videos, tax information and up to date news items on the industry's next big revenue opportunity.

new!
poollifts.
com

NEW! POOL LIFT CONFIGURATOR

Which pool lift is right for you? Pools vary greatly, so provide us with some basic information about your pool, and let us suggest the best lift for your application. Visit www.poollifts.com to try it today!

chairs



Mobile Aquatic Chair (MAC) **NEW**

Mobile Aquatic Chairs (MAC) are essential for facilities utilizing a ramp, zero-depth entry or movable floor. The MAC is built specifically for use in aquatic environments and with proper maintenance, will look great for years to come.

- Rear stabilizing wheels provide increased stability when the chair is in the water
- Arm rests flip up—enabling easy transfer on and off the chair
- 300 lb/136 kg weight capacity
- Powder coated stainless steel frame—looks beautiful and resists corrosion
- 18 inch/46 cm rotomolded plastic seat—rigid platform provides transfer support

ADA (AMERICANS WITH DISABILITIES ACT)

The Americans with Disabilities Act requires public accommodations to provide goods and services to people with disabilities on an equal basis with the rest of the general public. The goal is to afford every individual the opportunity to benefit from our country's businesses and services, and to afford our businesses and services the opportunity to benefit from their patronage. In our case, the goal is to provide access to every swimming pool, so that people with disabilities will have a greater opportunity to enjoy the benefits of water-based activities.

PURPOSE OF THIS GUIDE

This guide will help you identify the accessibility requirements and solutions for swimming pools in order to meet your obligations under the ADA.



ada compliance = product + installation

ADA POOL LIFT REQUIREMENTS AS OUTLINED IN SECTION 1009.2 OF THE ADA ACCESSIBILITY GUIDELINES		
REQUIREMENT*	POOL SPECIFIC	POOL LIFT SPECIFIC
Water depth at point of lift entry is no more than 48".	■	
When over the deck, the center line of seat is at least 16" from the edge of the pool.	■	
There is a 36" x 48" area of clear deck space on the side of the seat opposite the pool. Measurement starts at the rear edge of the seat. (Figure 3, page 7)	■**	■**
Seat is 16"-19" from the deck to the top of the seat surface.		■
In the loading area, the slope of the deck is no greater than 1:48.	■	
Seat is at least 16" wide.		■
There are footrests that move with the seat.		■
Armrests (optional) are removable or fold clear of the seat to allow the user to easily load the lift.		■
The lift is user operable from both the deck and water.		■
The seat submerges at least 18" into the water.	■***	■***
Lifting capacity is at least 300 pounds.		■

*For complete guidelines see Section 1009.2 of the ADA regulations at www.ada.gov
 **Some requirements may impact both the site requirement and pool lift requirement.
 ***Deck to water height combined with the reach of the pool lift arm will determine if the 18" minimum can be reached.

SECTION 1 IS THE FACILITY SUBJECT TO ADA LAWS?

THE FACILITY IS:		
QUESTIONS	✓	SOLUTIONS:
A Public Entity (Title II)		<i>If checked, continue to Section 2.</i>
Privately Owned (Title III)		<i>If checked, continue to Section 2.</i>
Private Home		<i>STOP, this facility is not subject to ADA guidelines.</i>
Apartment Pools* <i>*Apartment pools are only subject to ADA guidelines if they are open to the public at any time.</i>		<i>If the apartment's pool use is restricted to residents and their guests. STOP. If the apartment's pool is open to the public, continue to Section 2.</i>
Home Owner's Association Pools* <i>*HOA pools are only subject to ADA guidelines if they are open to the public at any time.</i>		<i>If the HOA's pool use is restricted to residents and their guests, STOP. If the HOA is open to the public, continue to Section 2.</i>
Condominiums* <i>*Condominiums are only subject to ADA guidelines if they are actively rented to the public, like a hotel.</i>		<i>If the condominium's pool use is restricted to residents and their guests. STOP. If the condominium's pool is open to the public, continue to Section 2.</i>

SECTION 2 COMPLIANCE REQUIREMENTS

Pool lifts and sloped entries (ramps) are the required primary means of access for swimming pools. Additional means of access are recognized (i.e. Transfer Walls, Transfer Systems, Stairs) but only as secondary measures. Pool lifts and sloped entries may also be used to meet secondary means of access requirements.

PERMITTED MEANS OF ACCESS					
APPLICATION TYPE	POOL LIFT	SLOPED ENTRY	TRANSFER WALL	TRANSFER SYSTEM	STAIRS
Means of Access	Primary		Secondary		
Swimming Pool <300 Linear Feet (1 means of access required)	■	■			
Swimming Pool >300 Linear Feet (2 means of access required —1 must be a primary means)	■	■	■	■	■
Wave action, lazy river, and other pools where user entry is limited to one area	■	■		■	
Wading Pools		■			
Spas	■		■	■	

POOL INFORMATION:

Sketch the facility's pool / spa layout here.

THE POOL SIZE IS:

QUESTIONS	✓	SOLUTIONS:
Linear pool wall is 300' or greater		<i>Two means of access are required and one must be a pool lift or sloped entry.</i>
Linear pool wall is less than 300'		<i>One means of access is required and must be a pool lift or sloped entry.</i>

SECTION 3

PRIMARY MEANS OF ACCESS FOR SWIMMING POOLS

This guide can be used to determine the appropriate means of access for facilities with no existing means OR to evaluate the compliance of an existing means of access. Any items that are unchecked need to be corrected for the means of access in order to be ADA compliant.

POOL LIFT		
QUESTIONS	✓	SOLUTIONS IF NO:
The lift is capable of unassisted operation.		<i>Replace lift with one that meets specification.</i>
The seat is at least 16" wide.		
The seat can be stopped between 16"–19" over the deck. (Fig. 1, Pg. 7)		
The lifting capacity is at least 300 pounds.		
There is a footrest that moves with the seat.		
The water depth at point of lift entry is no more than 48".		<i>Move lift to different location. If entire pool is deeper than 48", place lift where convenient.</i>
At the loading position, the centerline of the seat is at least 16" from the edge of the pool. (Fig. 2, Pg. 7)		<i>Move lift to different location, or replace lift with one that meets specification.</i>
In the loading position, the slope of the deck is no greater than 1:48.		<i>Move lift to different location, or adjust sloping on deck.</i>
On the side of the seat opposite the water, a clear deck space shall be provided parallel with the seat. The space shall be 36" wide minimum and shall extend forward 48" minimum from a line located 12" behind the rear edge of the seat. (Fig. 3, Pg. 7)		<i>Move lift to different location, or replace lift with one that meets specification.</i>
The submerged depth of the seat is at least 18" below the stationary water level. (Fig. 4, Pg. 7)		<i>Replace lift with one that meets specification.</i>
SLOPED ENTRY		
QUESTIONS	✓	SOLUTIONS IF NO:
The slope ratio is a maximum of 1:12		<i>If the sloped entry does not meet ADA requirements you may add an ADA-compliant pool lift as an approved means of access, or remodel the existing slope.</i>
The ramp is at least 36" wide.		
The sloped entry extends to a depth of 24"–30" maximum below the stationary water level. (Fig. 5, Pg. 7)		
If the ramp is longer than 30', there is an intermediate landing.		
Handrails are provided on both sides of the ramp.		<i>Add handrails.</i>
The distance between the handrails is between 33"–38".		<i>Change the design or location of the handrails.</i>
Height of the handrails is between 34"–38".		
The handrails are between 1.25"–2.0" outside diameter (OD).		<i>Replace the handrails with rails that meet the specification.</i>
The cross slope of the ramp is no greater than 1:48		<i>If an update to the ramp is cost prohibitive, a pool lift may be a more readily achievable means of access.</i>

SECTION 4 SECONDARY MEANS OF ACCESS

Use the checklist to determine if the pool's current means of access complies with the ADA requirements. Any items that are unchecked need to be corrected for that means of access to be ADA compliant.

POOL LIFT		
SEE PAGE 4 FOR CHECKLIST		
SLOPED ENTRY		
SEE PAGE 4 FOR CHECKLIST		
ACCESSIBLE STAIRS		
QUESTIONS	✓	SOLUTIONS IF NO:
The steps have uniform riser heights.		<i>Replace the stairs with a set that meet the specification, or use a different means of access.</i>
The step risers are not open.		
The depth of each tread is at least 11", measured from riser to riser.		
There are handrails on both sides.		<i>Add handrails.</i>
The distance between the handrails is between 20"–24".		<i>Modify the handrails to meet the specification.</i>
The top gripping surface of the handrails is between 34"–38".		
The handrails are between 1.25"–2.0" outside diameter (OD).		<i>Replace the handrails with a set that meet the specification.</i>
TRANSFER WALL		
QUESTIONS	✓	SOLUTIONS IF NO:
The height of the wall is between 16"–19" above the pool deck.		<i>Relocate the transfer zone to an area that meets the specification, or use a different means of access.</i>
The depth of the wall is between 12"–16".		
The length of the transfer wall is at least 60".		
There is at least 60" x 60" area of clear deck space at the bottom of the transfer wall. (Fig. 6, Pg. 7)		
The slope of the clear deck space is no greater than 1:48.		
There is at least one grab bar attached to the top of the pool wall.		<i>Attach at least one grab bar to assist in transfers.</i>
The grab bars are between 1.25"–2.0" outside diameter (OD).		<i>Replace grab bar with one that is the proper size.</i>
The top gripping surface of the grab bars is between 4" and 6" above the pool wall.		
The surface of the top of the pool wall is smooth with rounded edges.		<i>Modify top of pool wall to meet specification.</i>
The grab bars are perpendicular to the pool and extend the full width of the top of the pool wall.		<i>Replace grab bar with one that is the proper size.</i>
IF ONE GRAB BAR:		
It is centered on the clear deck space adjacent to the wall. (Fig. 6, Pg. 7)		<i>Relocate grab bar to proper position.</i>
It is located so that there is at least 24" of clearance on either side of the bar. (Fig. 7, Pg. 7)		
IF TWO GRAB BARS:		
There is at least 24" clearance between the two grab bars. (Fig. 8, Pg. 7)		<i>Relocate grab bars to proper position.</i>
The clear deck space is centered on the 24" clearance between the rails. (Fig. 9, Pg. 7)		

SECTION 4 CONTINUED

SECONDARY MEANS OF ACCESS

TRANSFER SYSTEM		
QUESTIONS	✓	SOLUTIONS IF NO:
The height of the top of the platform is between 16"–19" above the pool deck.		<i>Replace the platform with one that meets specifications.</i>
The platform is at least 19" deep by 24" wide.		
There is at least 60" x 60" of clear deck space centered on the 24" side of the platform. (Fig. 10, pg. 7)		<i>Relocate the transfer system to a different location, or use a different means of access.</i>
The slope of the clear deck space is no greater than 1:48.		
The height of each transfer step is no greater than 8".		<i>Replace the platform with one that meets specifications.</i>
The tread on each step is 14"–17" deep and at least 24" wide.		
There is a grab bar located on at least one side of each of the steps, and the platform.		<i>Add grab bars to meet specifications.</i>
The grab bars are between 1.25"–2.0" outside diameter (OD).		<i>Replace the grab bar with one that meets specifications.</i>
The top gripping surface of the grab bars is between 4"–6" above the pool wall.		
The surface of the top of the pool wall is smooth with rounded edges.		<i>Modify the top of the steps to meet this specification.</i>
The steps extends 18" below the stationary water level.		<i>Modify the transfer system to meet this specification, or use a different means of access</i>

SECTION 5

MEANS OF ACCESS FOR SPAS

Spas require one means of access regardless of the spa's size. The means of access can be either an ADA-compliant pool lift, transfer wall or transfer system. Use the checklists to determine if the spa's current means of access complies with the ADA requirements. Any items that are unchecked need to be corrected for the means of access to be ADA compliant.

NUMBER OF SPAS		
QUESTIONS	YES/NO	SOLUTIONS:
Is your spa part of a cluster of spas?		<i>If yes, 5%, or at least one of the spas must provide a means of access"</i>
POOL LIFT		
SEE PAGE 4 FOR CHECKLIST*		
<i>*Exception: Footrests are not required on pool lifts used with a spa.</i>		
TRANSFER WALL		
SEE PAGE 5 FOR CHECKLIST		
TRANSFER SYSTEM		
SEE PAGE 6 FOR CHECKLIST		

SECTION 6 FIGURES

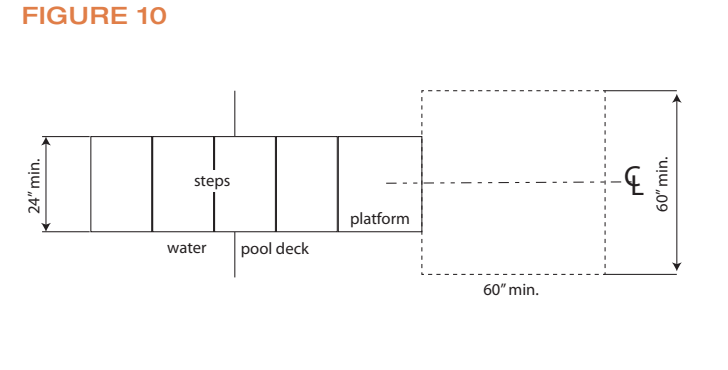
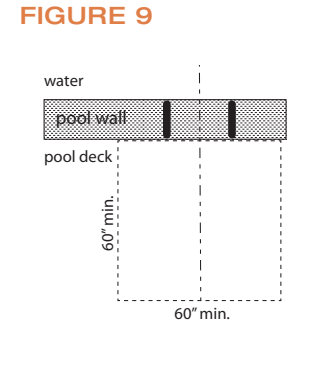
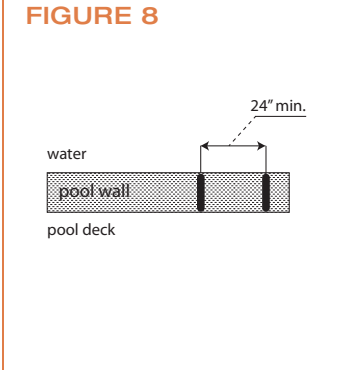
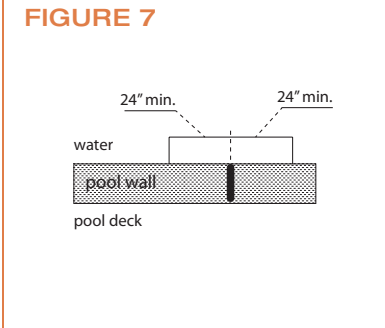
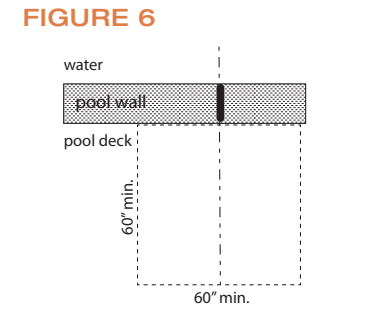
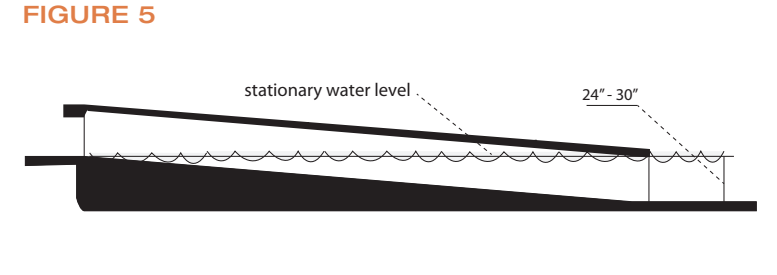
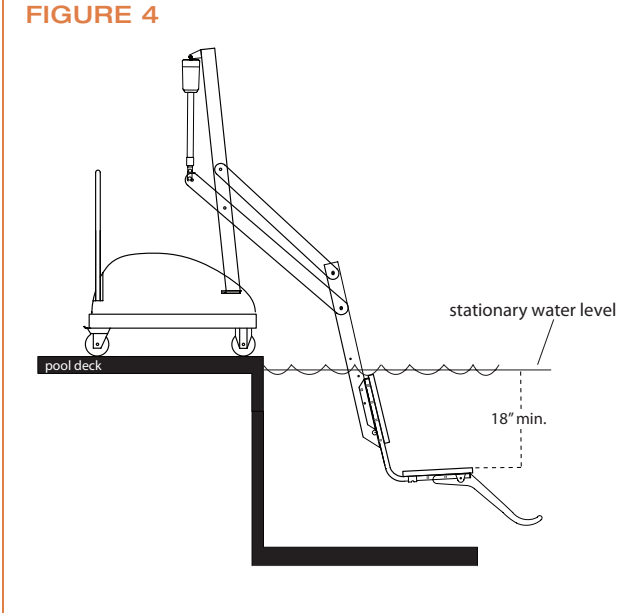
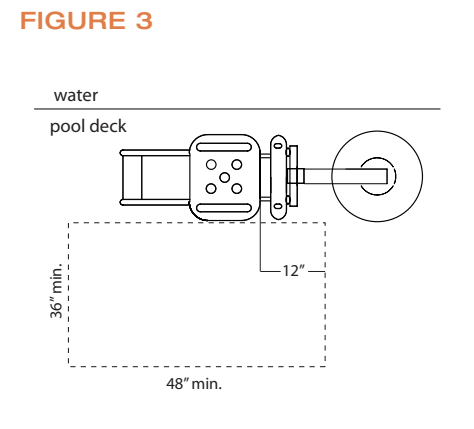
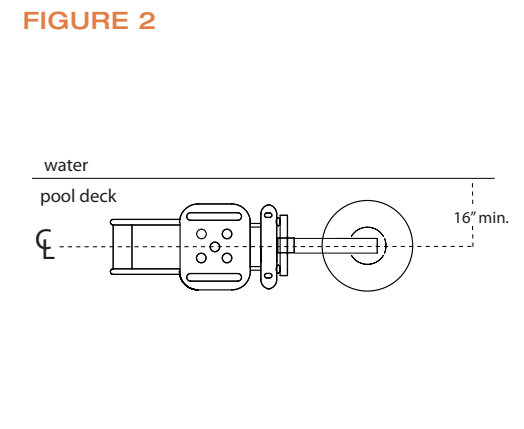
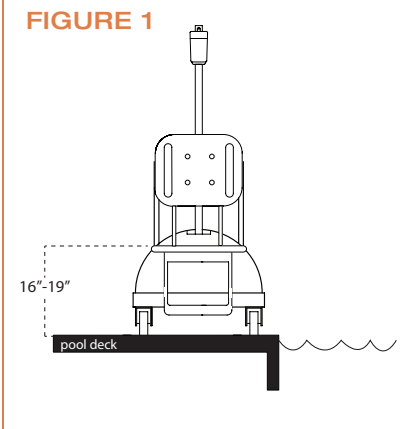

SECTION 7 MAINTENANCE OF ACCESSIBLE FEATURES

Routine lift maintenance and cleaning are an important part of ensuring accessibility. Regular service helps prolong the life of your lift, supports daily operation and helps satisfy the [ADA's Maintenance of Accessible Features*](#) provision.

*MAINTENANCE OF ACCESSIBLE FEATURES

The maintenance of accessible features provision of ADA states that “a public accommodation shall maintain in operable working condition those features of facilities and equipment that are required to be readily accessible to and usable by persons with disabilities.”

ELECTRONIC LIFT MAINTENANCE

Electronic lifts are mechanical in nature and contain a motor & gears. Much like an automobile there is a basic level of maintenance required to ensure proper operation. By instituting the following maintenance practices you can ensure optimal lift performance.

ACTIVITY	DAILY	WEEKLY	MONTHLY
Check/Charge battery	■		
Test for normal operation	■		
Inspect lift for damage	■		
Clean lift and seat, rinse with fresh water	■		
Wipe down (dry) lift after cleaning	■		
Cover/Store after use	■		
Spray/Lubricate all gears		■	
Inspect all cable connections			■
Inspect frame, mast, arms, seat			■
Inspect counter weight stack (portable lifts only)			■
Clean battery connections with nylon scouring pad			■
Clean metallic surfaces with cleaner wax			■

ADD AN EXTRA LAYER OF PROTECTION

Swimming pool chemicals, water and direct sunlight, when mixed together create a potentially corrosive environment for metallic based mechanical systems. This situation is particularly harsh in poorly ventilated indoor environments. The best way to guard against this potent combination of elements is to follow all lift maintenance guidelines, avoid storing your lift near pool chemicals and use a lift cover. Lift covers provide an extra layer of protection against the random splash of chemical infused water and the fading effects of direct sunlight.



aXs



The aXs is a perfect low profile lift for simple pool designs.

- ADA-compliant
- 300 lb/136 kg lifting capacity
- Easily removable from stainless steel deck anchor
- Powered by a 24-volt rechargeable battery
- User operable via a waterproof hand control
- 360° rotation
- Powder coated stainless steel and aluminum construction
- Includes battery, charger, battery console cover, waterproof control, stainless steel anchor socket with cover, footrest and seat belt assembly

PAL Series



Since its introduction in 1997, the PAL (Portable Aquatic Lift) has become the industry standard for portable swimming pool access. The completely portable PAL is the perfect accessory for any commercial aquatic facility.

- ADA-compliant
- 300 lb/136 kg lifting capacity
- Completely portable—easy to move by one person
- Conveniently stores away when not in use
- Powered by a 24-volt rechargeable battery
- User operable via waterproof hand control
- 240° rotation
- Powder coated stainless steel and aluminum construction
- Comes with battery, charger, battery console cover, waterproof control, footrest and seatbelt assembly

Splash! Series



This removable lifting system is designed for facilities seeking to provide user-friendly access to their swimming pools.

- ADA-compliant
- 400 lb/181.5 kg lifting capacity*
- Easily removable from stainless steel deck anchor
- Powered by a 24-volt rechargeable battery
- User operable via a waterproof hand control
- 359° rotation
- Powder coated stainless steel and aluminum construction
- Includes battery, charger, battery console cover, waterproof control, stainless steel anchor socket with cover, footrest and seat belt assembly

*Lifting capacity of the Extended Reach model is 300 lb/136 kg

Disclaimer: This Accessibility Compliance Guide by S.R. Smith, LLC does not constitute comprehensive training on ADA accessibility for aquatic facilities. When addressing accessibility issues, facilities should also comply with all local, state and federal laws, ordinances, codes, rules, regulations and standards ("legal requirements") which may have requirements above and beyond ADA law. Although this guide cites accessibility guidelines as set forth by the Access Board, it is impossible to ensure that the information provided is entirely accurate and up-to-date, or appropriate for any specific jurisdiction. This guide should only be used in conjunction with legal requirements and not as a replacement for those items. Failure to comply with legal requirements may result in serious legal consequences, even if the guidelines suggested in this publication have been followed. The information included in this publication is intended to be educational and informational in nature and is not intended to provide legal or medical advice or instruction regarding the accessibility of any aquatic facility.

UNDER NO CIRCUMSTANCES SHALL S.R. SMITH, LLC, THE AUTHORS OR EDITORS BE LIABLE FOR ANY DAMAGES, INCLUDING DIRECT, INCIDENTAL, SPECIAL, CONSEQUENTIAL OR EXEMPLARY DAMAGES THAT RESULT FROM THE USE OF THIS PUBLICATION OR THE INFORMATION CONTAINED THEREIN.



S.R. Smith, LLC
P.O. Box 400, 1017 SW Berg Parkway
Canby, Oregon 97013

P 503.266.2231 TF 800.824.4387 F 503.266.4334
www.srsmith.com www.poollifts.com

Copyright © 2011 S.R. Smith. All rights reserved. M-E-BRO-42